

SKiM[®] 4

IGBT Modules

SKiM401MLI07E4

Features

- IGBT 4 Trench Gate Technology
- Solder technology
- $V_{CE(sat)}$ with positive temperature coefficient
- Low inductance case
- Isolated by Al₂O₃ DCB (Direct Copper Bonded) ceramic substrate
- Pressure contact technology for thermal contacts
- Spring contact system to attach driver PCB to the control terminals
- High short circuit capability, self limiting to 6 x I_C
- Integrated temperature sensor

Typical Applications*

- UPS
- 3 Level Inverter

Remarks

- Case temperature limited to T_C = 125°C max, recommended T_{op} = -40 ... +150°C

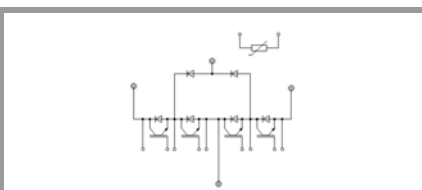

MLI

Absolute Maximum Ratings

Symbol	Conditions	Values	Unit	
IGBT				
V _{CEs}		650	V	
I _C	T _J = 175 °C	T _s = 25 °C	317	A
		T _s = 70 °C	250	A
I _{Cnom}		400	A	
I _{CRM}	I _{CRM} = 2xI _{Cnom}	800	A	
V _{GES}		-20 ... 20	V	
t _{psc}	V _{CC} = 360 V V _{GE} ≤ 15 V V _{CEs} ≤ 650 V	T _J = 150 °C	6	μs
T _J		-40 ... 175	°C	
Inverse diode				
I _F	T _J = 175 °C	T _s = 25 °C	266	A
		T _s = 70 °C	205	A
I _{Fnom}		400	A	
I _{FRM}	I _{FRM} = 2xI _{Fnom}	800	A	
I _{FSM}	t _p = 10 ms, sin 180°, T _J = 25 °C	2160	A	
T _J		-40 ... 175	°C	
Clamping diode				
I _F	T _J = 175 °C	T _s = 25 °C	266	A
		T _s = 70 °C	205	A
I _{Fnom}		300	A	
I _{FRM}	I _{FRM} = 2xI _{Fnom}	600	A	
I _{FSM}	t _p = 10 ms, sin 180°, T _J = 25 °C	2160	A	
T _J		-40 ... 175	°C	
Module				
I _{t(RMS)}	T _{terminal} = 80 °C	400	A	
T _{stg}		-40 ... 125	°C	
V _{isol}	AC sinus 50 Hz, t = 1 min	2500	V	

Characteristics

Symbol	Conditions	min.	typ.	max.	Unit
IGBT					
V _{CE(sat)}	I _C = 400 A V _{GE} = 15 V chipelevel	T _J = 25 °C	1.45	1.85	V
		T _J = 150 °C	1.70	2.10	V
V _{CE0}		T _J = 25 °C	0.9	1	V
		T _J = 150 °C	0.85	0.9	V
r _{CE}	V _{GE} = 15 V	T _J = 25 °C	1.4	2.1	mΩ
		T _J = 150 °C	2.1	3.0	mΩ
V _{GE(th)}	V _{GE} = V _{CE} , I _C = 6.4 mA	5	5.8	6.5	V
I _{CES}	V _{GE} = 0 V V _{CE} = 650 V	T _J = 25 °C			mA
		T _J = 150 °C			mA
C _{ies}	V _{CE} = 25 V		24.67		nF
C _{oes}	V _{GE} = 0 V		1.54		nF
C _{res}			0.73		nF
Q _G	V _{GE} = -8 V...+ 15 V		3200		nC
R _{Gint}	T _J = 25 °C		1.0		Ω

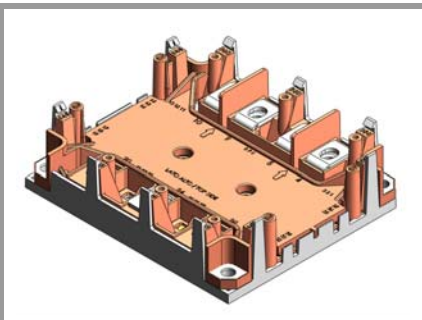

SKiM® 4

IGBT Modules

SKiM401MLI07E4

Features

- IGBT 4 Trench Gate Technology
- Solder technology
- $V_{CE(sat)}$ with positive temperature coefficient
- Low inductance case
- Isolated by Al_2O_3 DCB (Direct Copper Bonded) ceramic substrate
- Pressure contact technology for thermal contacts
- Spring contact system to attach driver PCB to the control terminals
- High short circuit capability, self limiting to $6 \times I_C$
- Integrated temperature sensor

Typical Applications*

- UPS
- 3 Level Inverter

Remarks

- Case temperature limited to $T_c = 125^\circ C$ max, recommended $T_{op} = -40 \dots +150^\circ C$

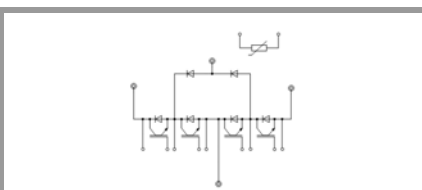

MLI

Characteristics						
Symbol	Conditions		min.	typ.	max.	Unit
$t_{d(on)}$	$V_{CE} = 300 V$ $I_C = 400 A$	$T_j = 150^\circ C$		149.14		ns
t_r		$T_j = 150^\circ C$		79.7		ns
E_{on}	$R_{G on} = 2 \Omega$	$T_j = 150^\circ C$		3.32		mJ
$t_{d(off)}$	$R_{G off} = 2 \Omega$	$T_j = 150^\circ C$		420		ns
t_f	$di/dt_{on} = 1112 A/\mu s$ $di/dt_{off} = 3801 A/\mu s$	$T_j = 150^\circ C$		180		ns
E_{off}		$T_j = 150^\circ C$		20.91		mJ
$R_{th(j-s)}$				0.25		K/W

Characteristics						
Symbol	Conditions		min.	typ.	max.	Unit
Inverse diode						
$V_F = V_{EC}$	$I_F = 400 A$ $V_{GE} = 0 V$ chipelevel	$T_j = 25^\circ C$		1.5	1.9	V
		$T_j = 150^\circ C$		1.6	2.0	V
V_{F0}		$T_j = 25^\circ C$	0.95	1.04	1.236	V
		$T_j = 150^\circ C$		0.85	0.99	V
r_F		$T_j = 25^\circ C$	0.8	1.2	1.8	m Ω
		$T_j = 150^\circ C$		1.8	2.6	m Ω
I_{RRM}						A
Q_{rr}	$V_{GE} = -15 V$ $V_R = 300 V$			24		μC
E_{rr}						mJ
$R_{th(j-s)}$	per diode			0.35		K/W
Clamping diode						
$V_F = V_{EC}$	$I_F = 300 A$ $V_{GE} = 0 V$ chipelevel	$T_j = 25^\circ C$		1.4	1.8	V
		$T_j = 150^\circ C$		1.4	1.8	V
V_{F0}		$T_j = 25^\circ C$	0.95	1.04	1.236	V
		$T_j = 150^\circ C$		0.85	0.99	V
r_F		$T_j = 25^\circ C$	0.8	1.2	1.8	m Ω
		$T_j = 150^\circ C$		1.8	2.6	m Ω
I_{RRM}				127		A
Q_{rr}	$V_{GE} = -15 V$ $V_R = 300 V$					μC
E_{rr}				1.8		mJ
$R_{th(j-s)}$	per diode			0.35		K/W
Module						
L_{CE}				22		nH
R_{CC+EE}	terminal-chip	$T_s = 25^\circ C$		1.35		m Ω
		$T_s = 125^\circ C$		1.75		m Ω
M_s	to heat sink (M5)		2		3	Nm
M_t	to terminals M6		4		5	Nm
w				317		g
Temperature Sensor						
R_{100}	$T_c = 100^\circ C$ ($R_{25} = 5 k\Omega$)			$493 \pm 5\%$		Ω
$B_{100/125}$	$R(T) = R_{100} \exp[B_{100/125}(1/T - 1/T_{100})]$; T[K];			$3550 \pm 2\%$		K

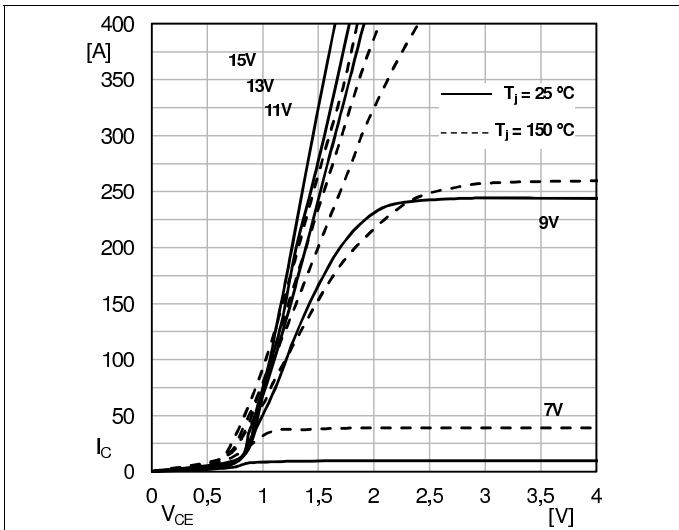

Fig. 3: Typ. IGBT output characteristic, inclusive R_{CC+EE}

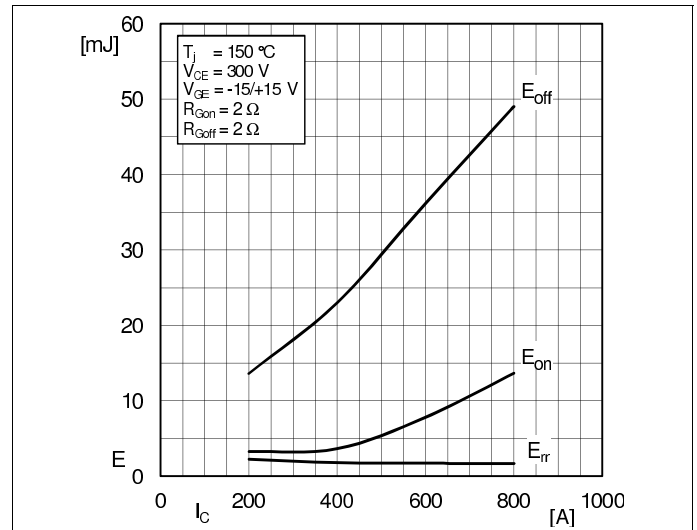

Fig. 6: Typ. turn-on /-off energy = $f(I_c)$

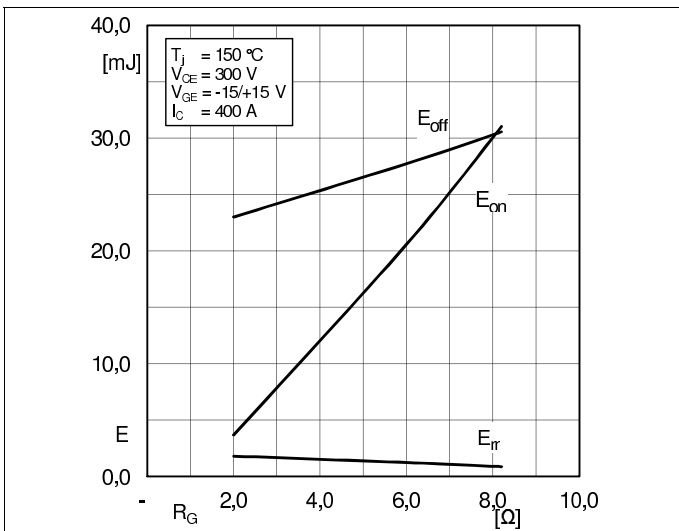

Fig. 8: Typ. turn-on /-off energy = $f(R_G)$

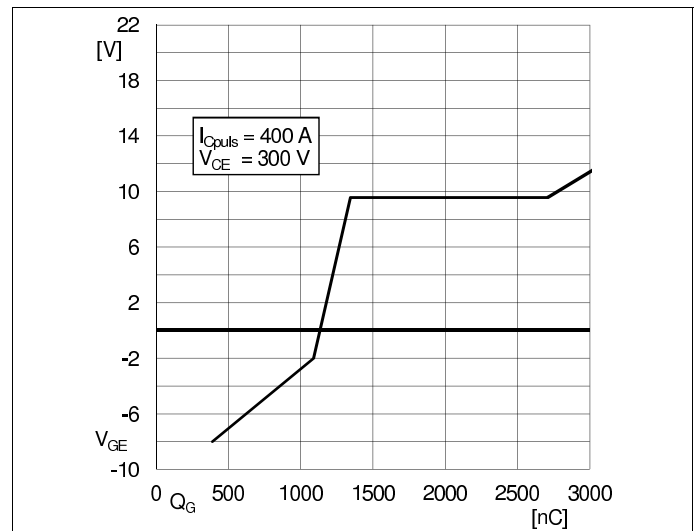

Fig. 10: Gate charge characteristic

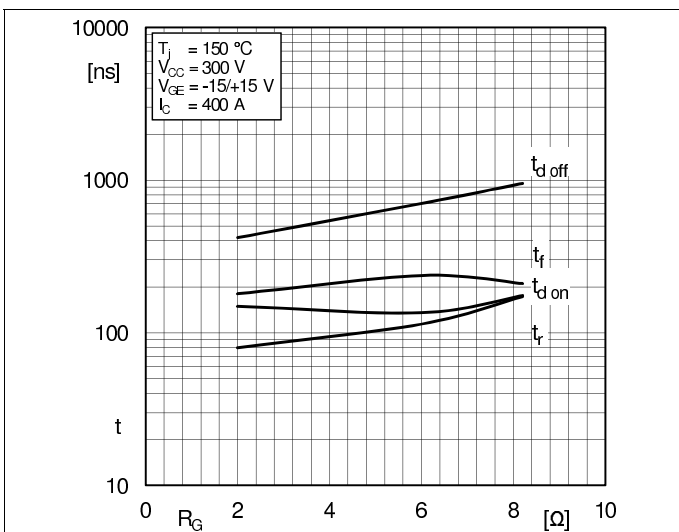

Fig. 12: Typ. switching times vs. gate resistor R_G

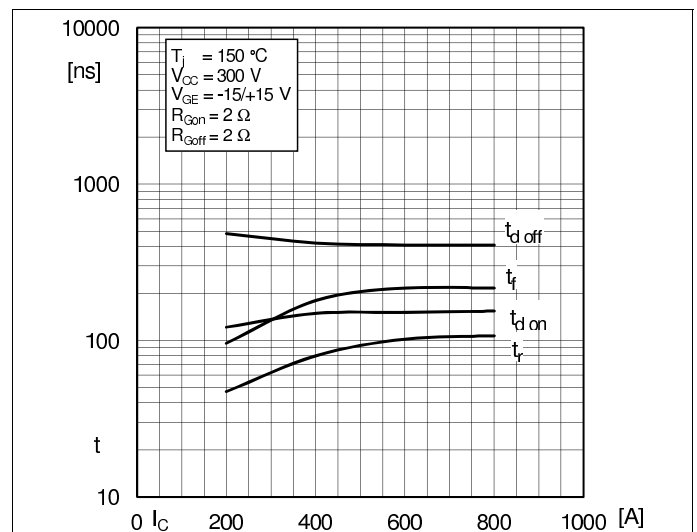

Fig. 14: Typ. switching times vs. I_c

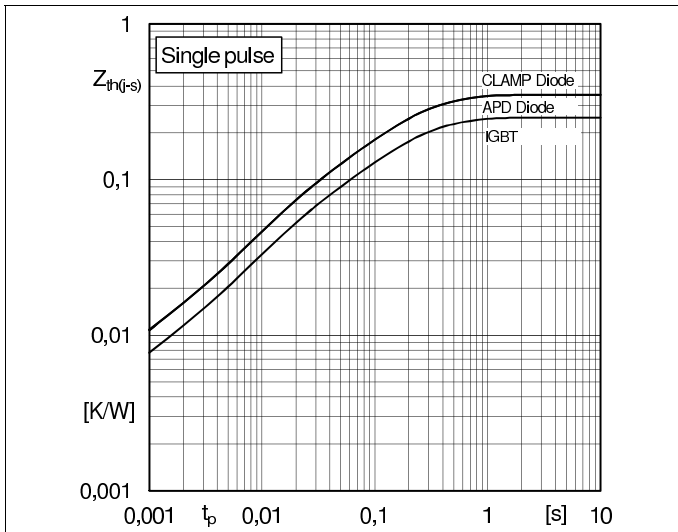
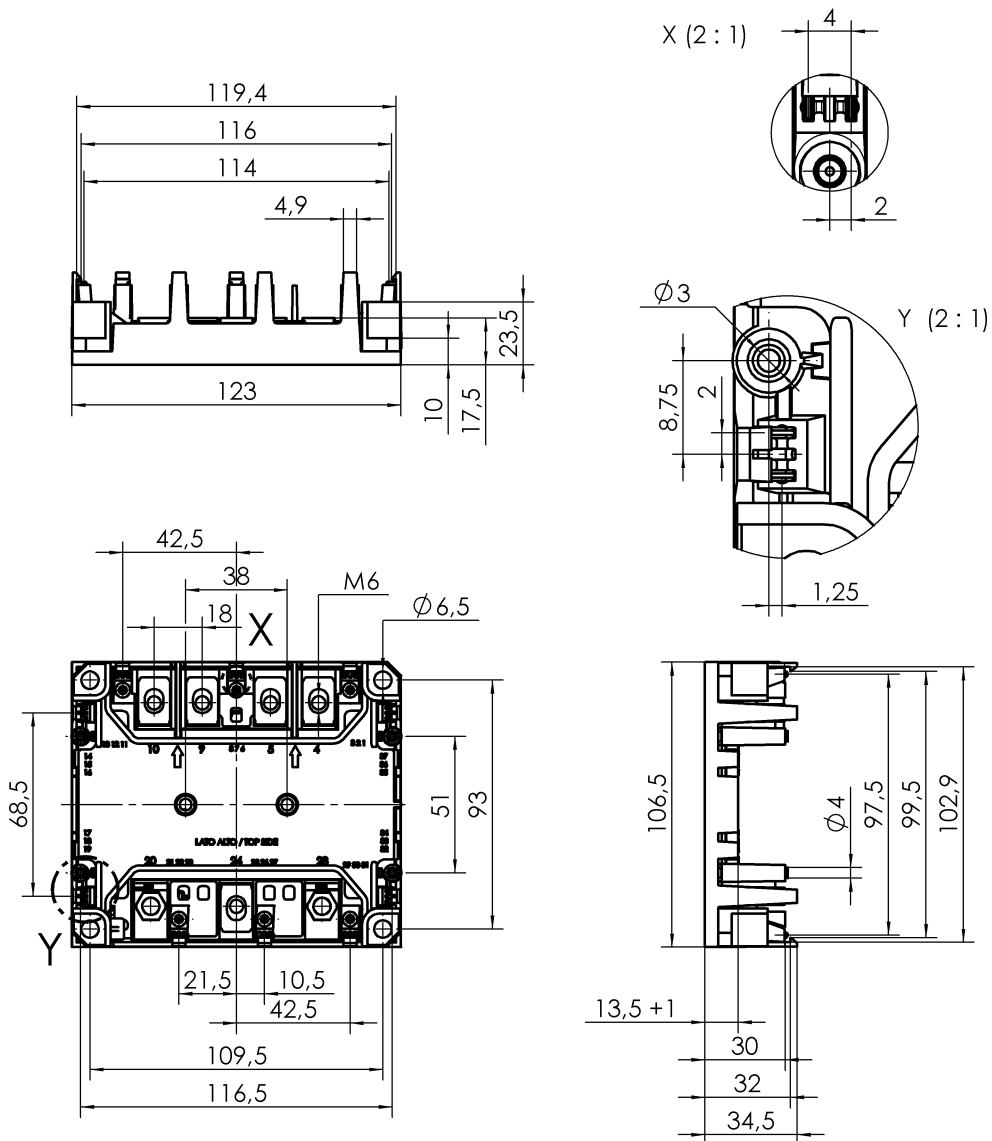
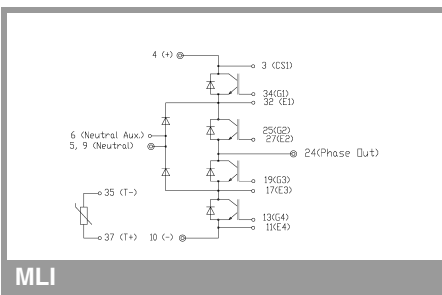

Fig. 15 Typ. IGBTs and DIODEs transient thermal impedance

SKiM401MLI07E4



SKiM 4



MLI

This is an electrostatic discharge sensitive device (ESDS), international standard IEC 60747-1, Chapter IX

* The specifications of our components may not be considered as an assurance of component characteristics. Components have to be tested for the respective application. Adjustments may be necessary. The use of SEMIKRON products in life support appliances and systems is subject to prior specification and written approval by SEMIKRON. We therefore strongly recommend prior consultation of our staff.